



## HB REFRIGERACION S.A

Conoce un poco de nosotros.

Somos una Empresa del rubro de refrigeración Industrial, comercial, aire acondicionado y ventilación que opera en el mercado peruano desde el año 2002, ofrecemos a nuestros distinguidos clientes Equipos y maquinarias innovadores de ultima tecnología, somos Importadores mayoristas , trabajamos con las mejores marcas del mercado mundial, proveedores de todo el mundo quienes nos avalan y brindan garantía directo de fábrica con certificado de calidad. Nuestra finalidad es cumplir con las normas establecidas para la cadena de frio, atendemos sectores como agroindustria, industria avícola, cárnica, láctea, pesca, industria alimentaria en general, empresas de almacenamiento, empresas logísticas, industrias químicas, laboratorios, supermercados, tiendas de conveniencias, Retail, Horeca, etc.





## EQUIPOS DE REFRIGERACIÓN

- Unidades Condensadora
- Evaporadores
- Condensadores
- Motores
- Compresores
- Moto ventiladores





# Copeland Discus™







# Refrigeración







**MODELO BNH-BNQ**





## Evaporadores de Doble Flujos y Cúbicos

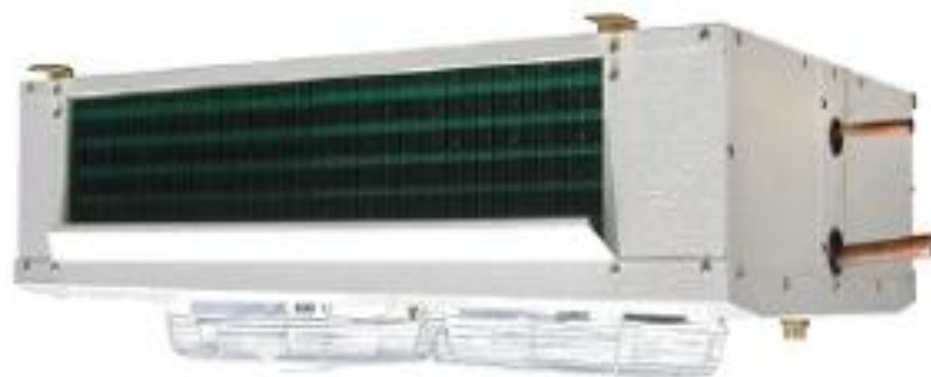



## UNIDADES CONDENSADORAS DHWHB CON COMPRESOR BITZER ALEMAN

Unidades Condensadoras DHW de Korea del Sur, equipadas con compresor Bitzer Alemán , Controles Danfoss-Dinamarca , Condensador con protección para ambientes corrosivos , Ventiladores EBM Paspt ( Alemanes ), con gabinete para exterior entre algunas de







A - Soplande







## PANELES Y PUERTAS PARA CAMARAS FRIGORIFICAS

## Puerta Frigorífica Polistamp – Italia

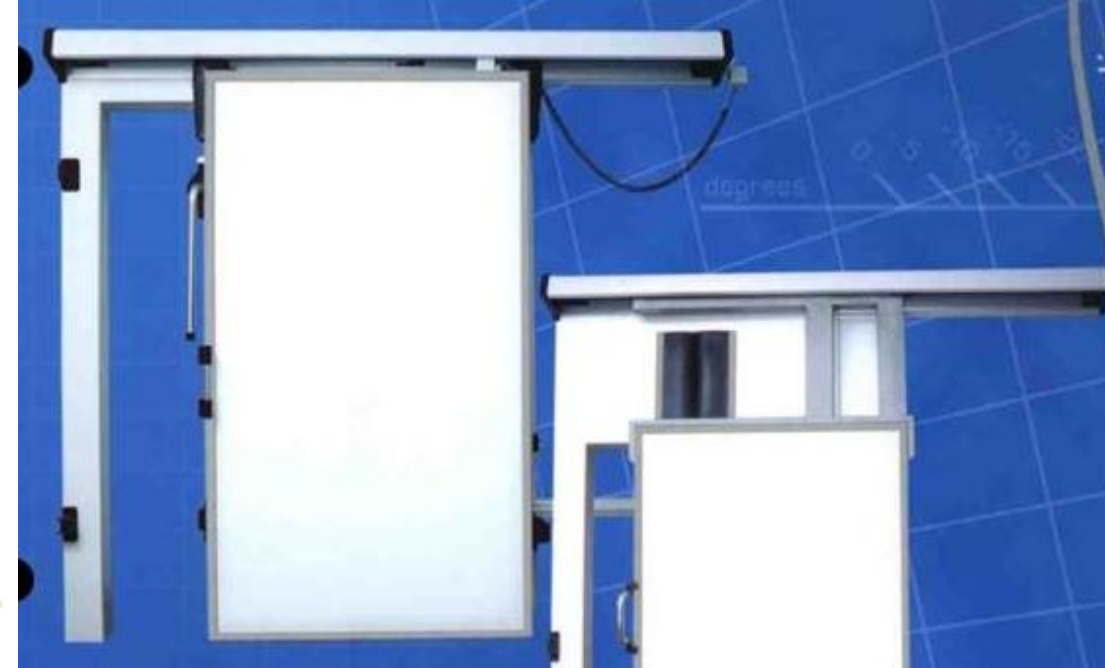
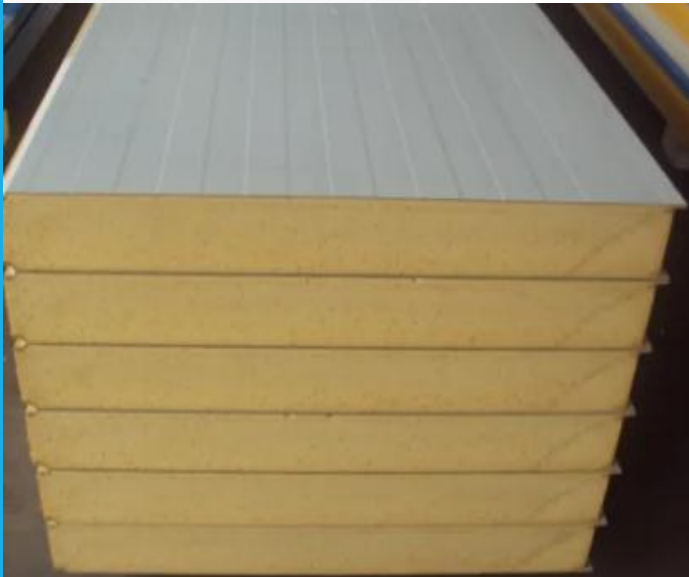
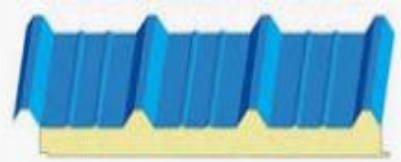
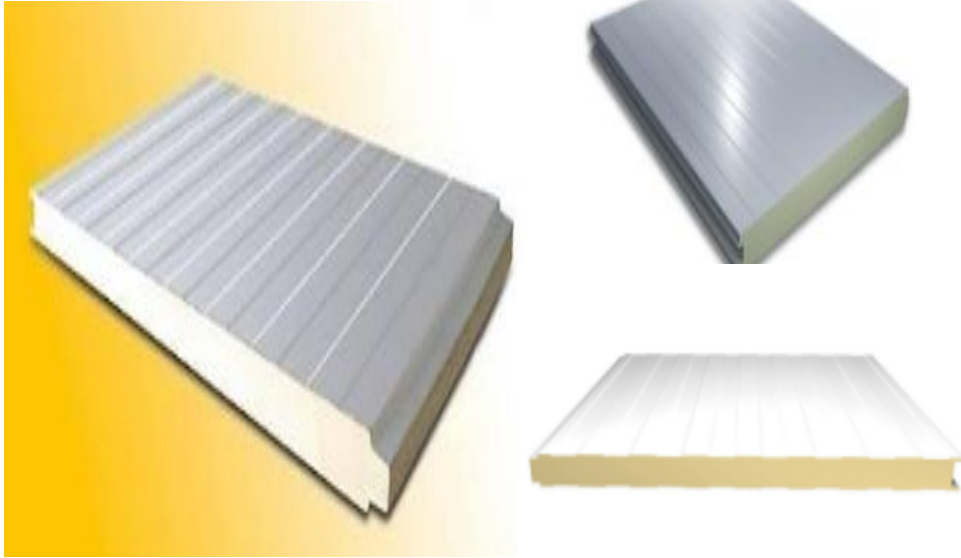



## PUERTA DE ROLLO RAPIDO







# TOLDO EN LONA DE PVC CON TEJIDO INTERNO DE POLIESTER











## SELLOS, NIVELADORES Y PUERTAS SECCIONALES



Sistema de Acoplamiento de vehículo antes de abrir la puerta lo que evita la pérdida de frío.

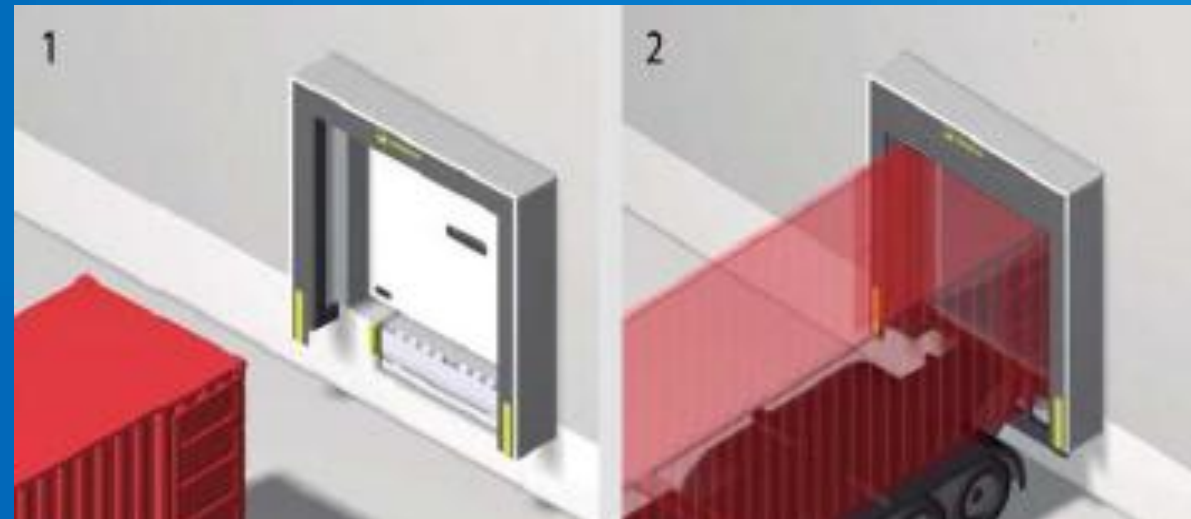

EL SOFTWARE

# Sitrad<sup>PRO</sup>

NO REQUIERE  
IP FIJA.



Full Gauge Controls  
para administración  
a distancia de las  
instalaciones de  
refrigeración,  
calentamiento,  
climatización y  
calentamiento solar.

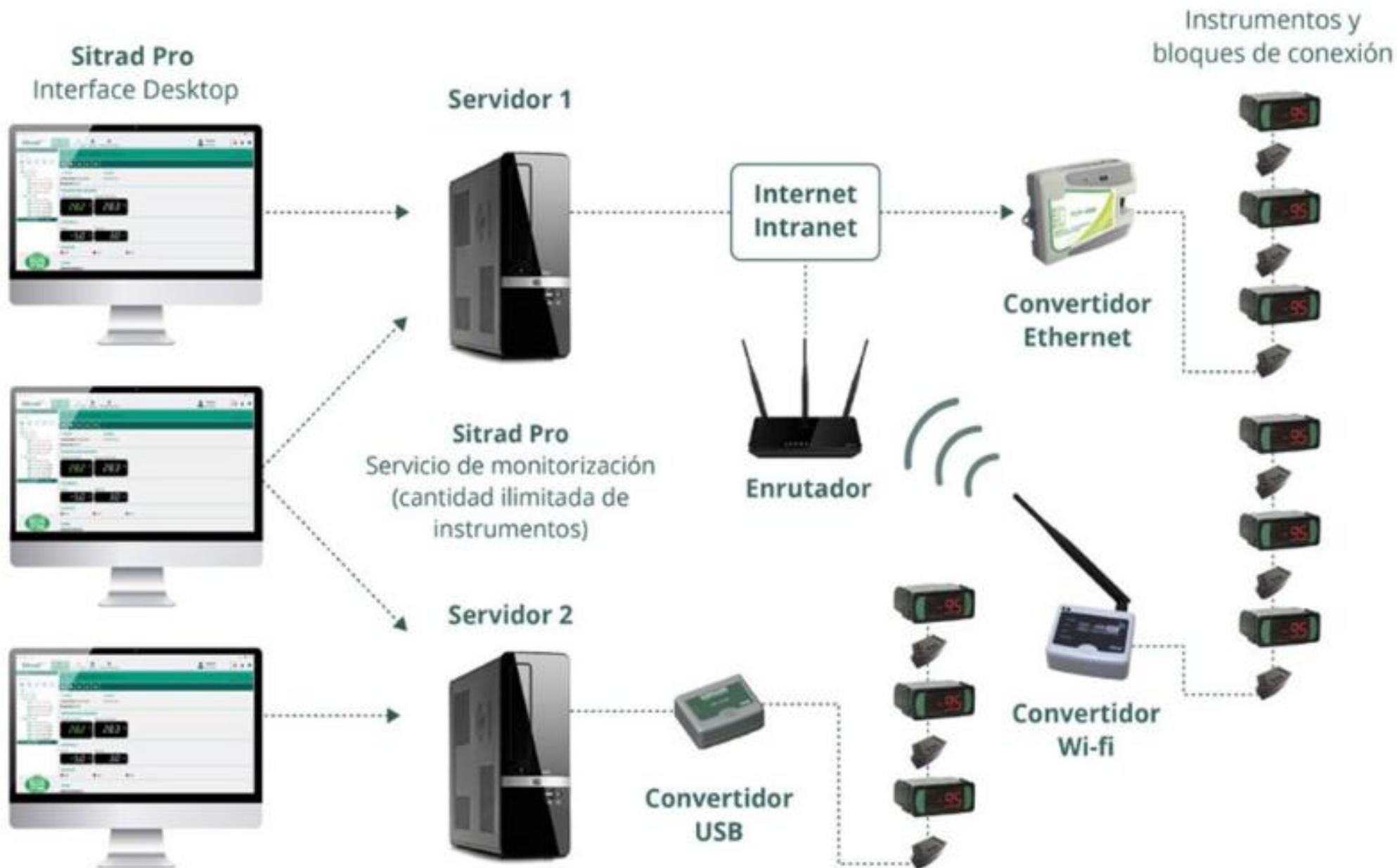



# CAREL

## Válvulas de Expansión Electrónica (EEV)

Hasta 14.3 % de ahorro de energía debido a la reducción del consumo de potencia en aplicaciones con Chillers

### EVD - Acessórios



Display



Ultracap



Cabo da válvula



Conversores tLan/USB

*Accesorios CAREL*



*EEV CAREL*

**TUNELES IQF**





Panel Frigorífico

# ISOTERM

1125



## Metalpanel



Panel Frigorífico

## Seguridad

Minimizar los potenciales peligros en su instalación

La generación de espumas PIR que cumplen con las exigencias del ensayo SBI, a la vez que mantienen unas propiedades mecánicas y aislantes del panel óptimas, son la mejor garantía en Seguridad.

## Sostenibilidad

Contribución a la sostenibilidad ambiental

Los materiales de Metalpanel utilizados como elementos constructivos en la Industria del Frío, reducen el impacto de los combustibles fósiles en la atmósfera; propiciando construcciones frigoríficas sostenibles ambientalmente. Además las espumas eco-panel que fabricamos no provocan daño a la capa de Ozono (cero ODP).

# Tecnología CESS

## Conservación

Objetivo de Metalpanel: la conservación de sus productos

El almacenamiento frigorífico a gran escala y las exigencias de duración de la vida de los productos, nos han llevado al desarrollo de una nueva línea de paneles aislantes tanto en espumas PUR como PIR a través de nuestra gama Stop-Fire.



## Energía

El frío es Energía

Si el hielo de la fotografía se fundiese, una energía ingente se perdería definitivamente. El gran atractivo de nuestros materiales es conseguir un menor aporte de energía para conservar el frío.



## Perfiles sanitario MPM para cámara frigoríficas

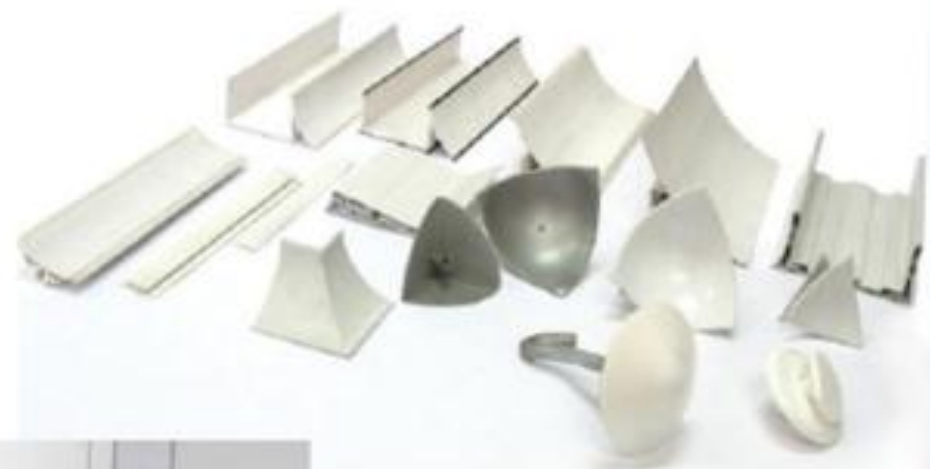

 **mpm**  
PLASTIC PROFILES



## Puerta Frigorífica Polistamp – Italia.





## GASES REFRIGERANTES

## TANQUE RECUPERADOR DE REFRIGERANTE - AITCOOL





## Cortinas de Aire Industriales y Super Industriales



- ❖ Bajo ruido y alta eficiencia con ventiladores tipo Sirocco
- ❖ Velocidades de aire optimizadas para Baja, Media y Alta.
- ❖ Pueden llegar a actuar de barrera contra el humo del fuego
- ❖ Hasta 4mt Tiro de Aire, para Cort. Super Industriales Hasta 7 mt
- ❖ Con control remoto y fácilmente operable con un solo click



BUGS



DUST



HOT AIR



COLD AIR



FUMES

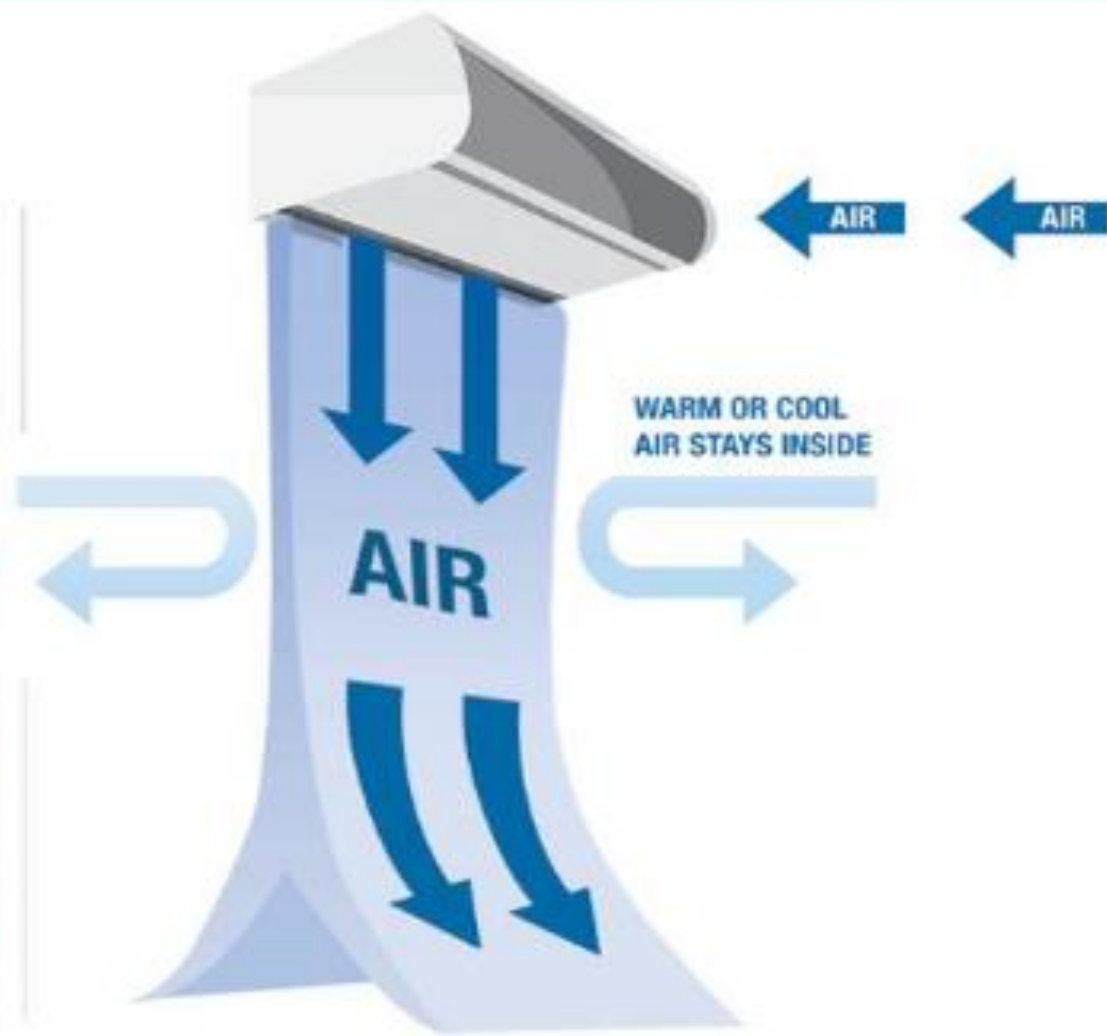

# AIR WALL AirCurtain

**CORTINAS DE AIRE INDUSTRIALES Y SUPER INDUSTRIALES**

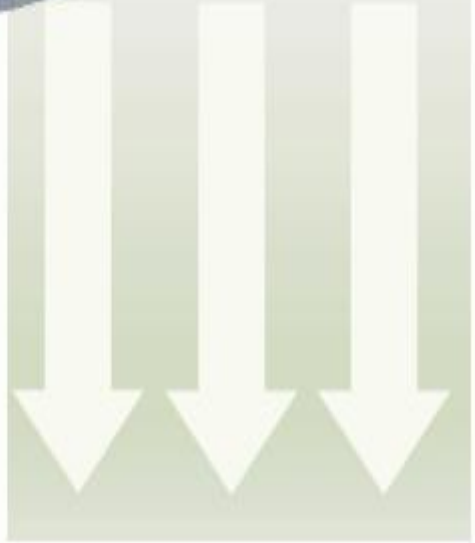





**AIRE ACONDICIONADO CON REFRIGERANTE ECOLOGICO**



**Split Pared**  
**Inverter 16 SEER - R410a**

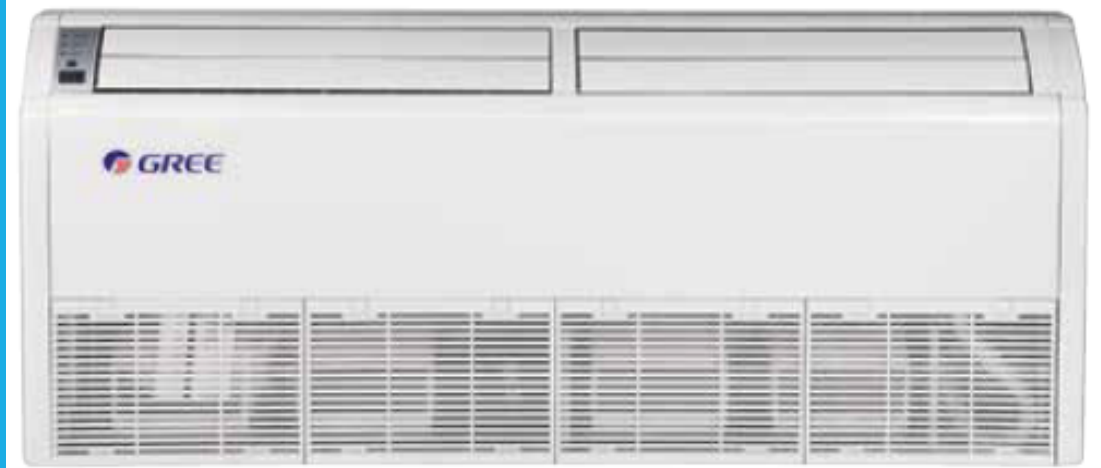

**Split Piso-techo**  
**On/Off - R410a**  
**Frio sólo**



## BOMBAS DE CONDENSADO

**SLIM BOX**



**MINI BOX**

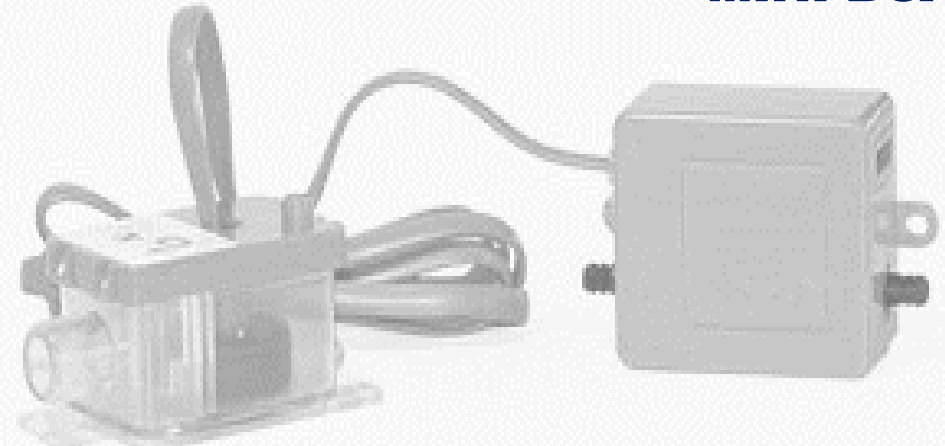

**TANK PUMP-V**



**HEART BOX**





TCV-09CSA/2  
TCV-12CSA/2  
TCV-18CSA/2  
TCV-24CSA/2



**Split Pared**  
Inverter 16 SEER - R410a



**Split Piso-techo**  
On/Off - R410a  
Frio sólo



**CORTINAS DE AIRE INDUSTRIALES Y SUPER INDUSTRIALES**



- BUGS
- DUST
- HOT AIR
- COLD AIR
- FUMES

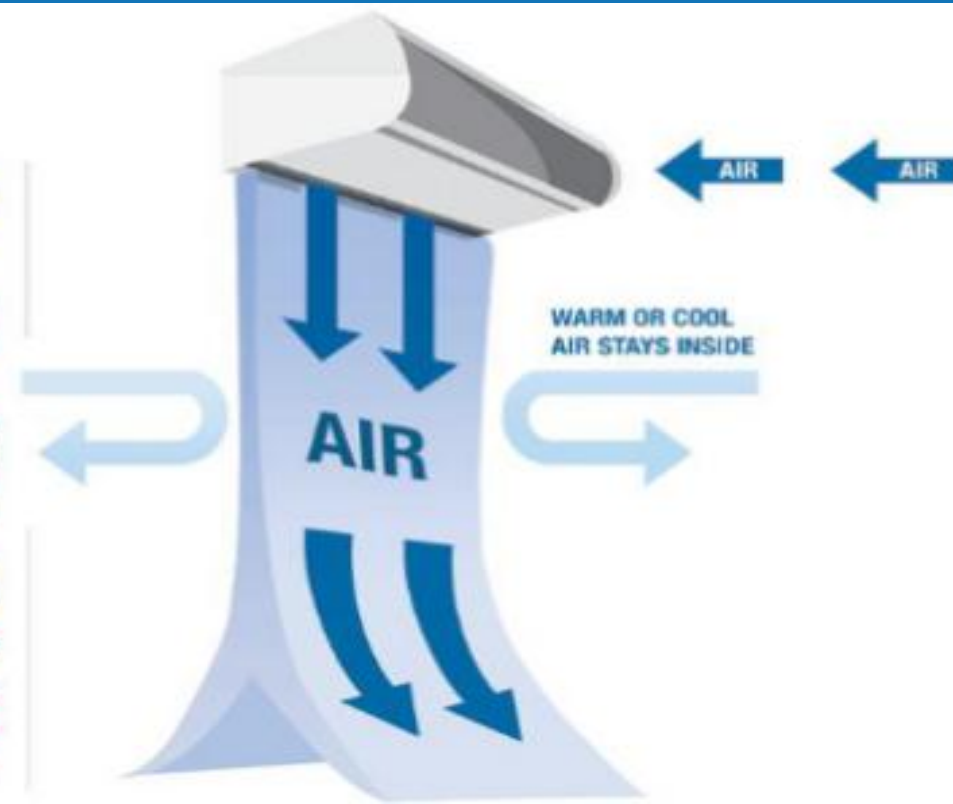

# GENERADOR DE HIELO EN ESCAMAS

In Touch



Catalog  
Geneglace



F600 ABF GENERA1



DUAL PACK 14





# SISTEMA DE FIJACION INOX

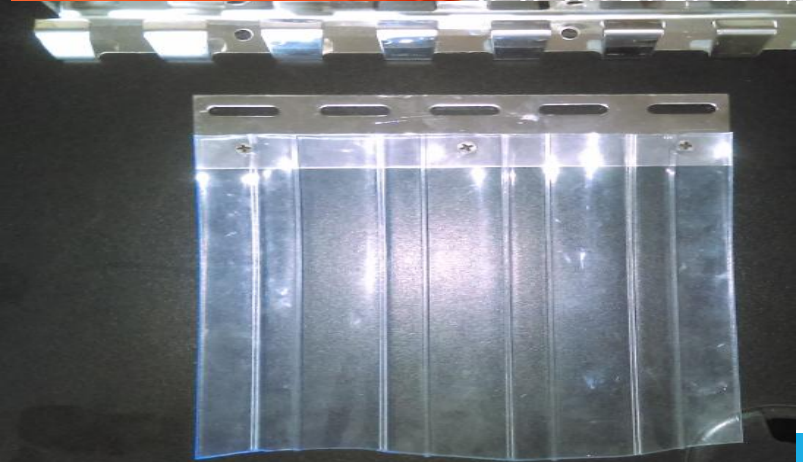

# CORTINAS SANITARIAS DE PVC

Standard Transparent  
Light Blue

Alta Temperatura  
Rollo: 50m  
-15°C hasta +50°C

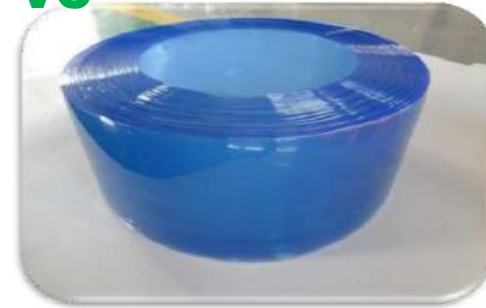

Anti-insect Transparent  
Orange

Rollo: 50m  
-15°C hasta +50°C

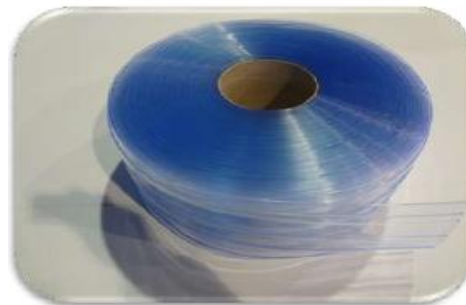

Polar Ribbed Light  
Blue

Baja Temperatura  
Rollo: 50m  
-40°C hasta +50°C



Polar Nylon Reinforced

Baja Temperatura  
Rollo: 50m  
-40°C hasta +50°C

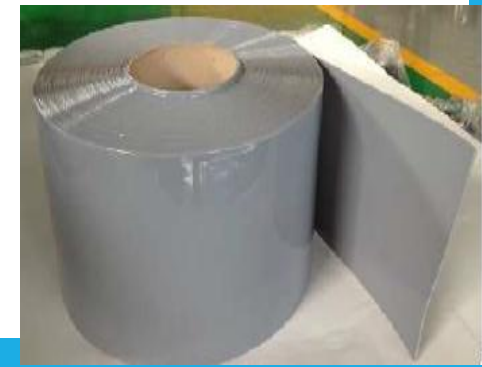



## CORTINAS MAGNETICAS DE PVC

Hechos de Materiales Magnéticos para asegurar el sellado tras una apertura ya sea por entrada o salida del personal o vehículos .

### APLICACIONES

- Bloquea el ingreso de parásitos e insectos
- Las Cortinas son Flexibles y Sanitarias
- Separación de área contaminadas
- Barreras contra el ruido
- Entre otros



High transparency

Good softness

Isolation noise



Magnetic stripe

Isolated air conditioning







**UNIDADES CONDENSADORAS , COMPRESORES Y EVAPORADORES EN LAS MEJORES MARCAS**



Idóneo para que los fabricantes de maquinaria del sector alimentario y de bebidas, el de manejo de material y el de procesamiento puedan controlar los motores de un modo preciso y eficaz. Su punto fuerte es el rendimiento de control, la seguridad funcional y una comunicación de fieldbus flexible.

Función integrada para un control mejorado

Contamos con la línea completa de variadores de frecuencia para toda aplicación







## VENTILADOR FRIGO EXPERT

- Los ventiladores de techo son **menos perjudiciales para la salud** ya que no resecan el aire, lo cual afecta la salud de la persona.
- Su **gasto energético** es menor que cualquier otro sistema de ventilación. Además de que no usan gases refrigerantes.
- Los ventiladores de techo son **fáciles de instalar**. Solo debes tener presente que, el techo donde vaya fijado en la habitación, tenga la altura apropiada, resistencia y una conexión eléctrica
- **No ocupan mucho espacio**, ya que van colgados al techo
- Silencioso
- Decorativo
- Alejan los insectos

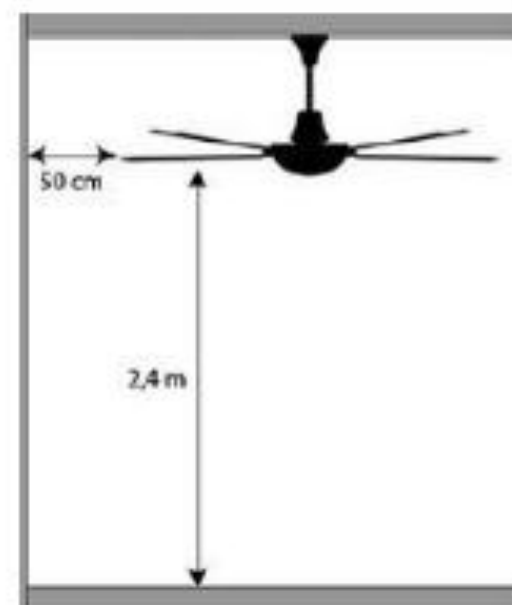





**CERREJO (BLOQUEO Y RECEPTOR) MODEL: HS 1179**  
**MATERIAL : ACERO INOXIDABLE**



**BISAGRA PARA PUERTA MODELO HS 1230A**  
**MATERIAL: ZINC FUNDIDO A ALTA PRESIÓN**



# Resistencias en General para Evaporadores Frigoríficos

## COMPANY CERTIFICATIONS

-  bsi ISO 9001 Quality Management FM 11235
-  CSQ eco 9191.IRCR
-  CSQ ENERGY 9196.IRC8
-  SGS IT-75.12-6975 12/054P\_IND EN 15085-2
-  SGS IT-75.12-6975 12/055P\_IND ISO 3834-3





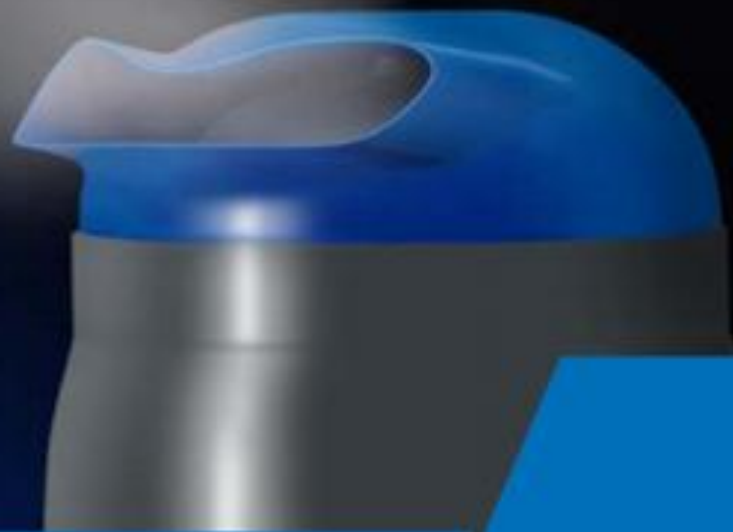

HUMIDIFICACIÓN  
EL ATOMIZADOR ROTATIVO PARA  
INDUSTRIAS, ALMACENES Y  
COMERCIOS. PULVERIZACIÓN EN  
TODAS LAS DIRECCIONES.

CONDAIR ABS3



 **condair**

**CONDAIR ABS3**

HUMIDIFICACIÓN



Bajo pedido: Pulverización  
en todas direcciones



Renovación de agua:  
120 veces por hora.



Regulación continua

## TÚNEL DE DESINFECCIÓN PARA PERSONAL

Ideal para uso en:

**Hospitales**

**Laboratorios**

**Restaurantes**

**En la Industria**

**NUEVO  
PRODUCTO**

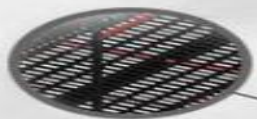
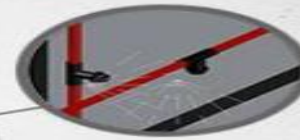

### USO

#### EN HOSPITALES Y LABORATORIOS

- Pisos, techos y paredes
- Cuartos de baño
- Ropa (ultimo enjuague)
- Guantes y botas (de limpieza)

#### EN RESTAURANTES

- Equipos y maquinas, mesas, pisos, techos paredes y utensilios
- Limpieza de congeladoras y equipos de congelación.

#### EN EL HOGAR

- Servicios higiénicos y duchas
- Utensilios de cocina
- Pisos y paredes de todo tipo de material
- Limpieza de tanques y cisternas

#### EN LA INDUSTRIA

- Equipos de refrigeración
- Salas de almacenaje y fabricación
- Pisos, techos y paredes
- Limpieza de tanques y cisternas

#### EN COLEGIOS, CLUBES, LUGARES DE RECREO

- Lavado de piscinas y cisternas
- Ambientes (salones, camerinos, aulas)
- Pisos, techos y paredes



## Puerta corredera



**En stock , entrega inmediato**

### **Aplicación :**

Industria alimentaria, industria, supermercado, almacenamiento, industria farmacéutica y venta minorista

**Temperatura :** -45 °C ~ +5 °C

### **Marco:**

La superficie está hecha de espuma de poliuretano como una estructura completa. Alcanzando una superficie lisa y proporcionando buenos valores de aislamiento. Además, está equipado con un sistema de limitación de temperatura, no más control de temperatura u operación manual

### **Hoja:**

La superficie está hecha de espuma de poliuretano como una estructura completa. Alcanzando una superficie lisa y proporcionando buenos valores de aislamiento.

**Material de superficie estándar:** acero inoxidable, acero coloreado, aluminio.

## Ventiladores Maer Fan Motor

Disponibles en Diámetros de: 400,450,500, 550 y 630mm:



- YSWF68L35P2-360N-300 (220V/380V/440V, 60HZ, 4 POLES, 3PH, CL.F,Δ/Y, SUCTION)
- YSWF74L47P4-470N-400 (220/380V/440V, 60HZ, 4 POLES, 3PH, CL.F,Δ/Y, SUCTION)
- YSWF74L60P4-522N-450 (220V/380V/440V, 60HZ, 4 POLES, 3PH, CL.F,Δ/Y, SUCTION)
- YSWF102L40P4-570N-500 (220V/380V/440V, 60HZ, 4 POLES, 3PH, CL.F,Δ/Y, SUCTION)
- YSWF102L50P6-635N-550 (220V/380V/440V, 60HZ, 6 POLES, 3PH, CL.F,Δ/Y, SUCTION)
- YSWF102L70P6-753N-630 (220V/380V/440V,60HZ, 6 POLES, 3PH, CL.F,Δ/Y, SUCTION)
- YZF25-40(220V,60HZ) Motor de Ventilador 90W

**Con certificación**

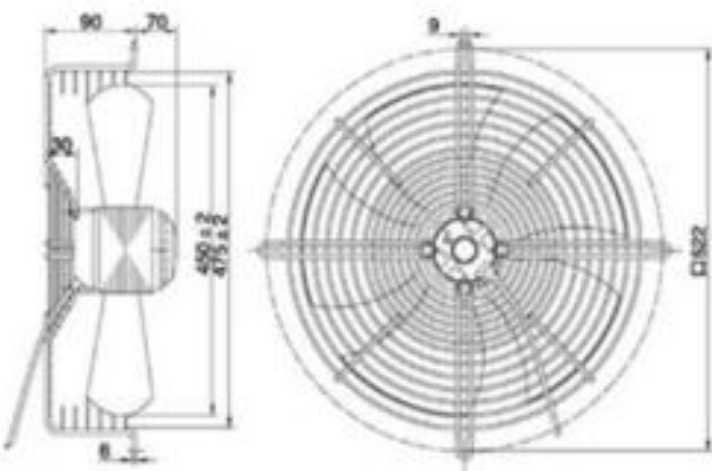



## ACEITES PARA TODO TIPO DE COMPRESORES BITZER

ACEITES BITZER	ACEITE ALTERNATIVO	FABRICANTE
B100	Alkyl 100E	BVA
	Zerice S100	EXXON Mobile
	SHC427	Mobil
B150SH	CP4214-150	CPI
BSE170	Enersyn MP-5 170	BP
	Solest 170	CPI
	Emkarate RL 170 H	Uniqema
	Reniso SE 170	Fuchs
B320SH	BVA320	BVA
B5.2 (AB 150)	Zerice 546, S68	EXXON Mobile
	Zerol 150	Petrosynthese
	Clavus SD2212	Shell
	Reniso SP32, SP46	Fuchs
BSE32 (POE 32)	Clavus R32	Shell
	RL32 H	Uniqema
	SEZ32	Fuchs
	Castrol ICEMATIC SW32	Deutsche BP
	EAL Arctic 22 CC, 32	EXXON Mobile
	Solest 31-HE	CPI
	Solest 68	CPI
BSE55 (POE 68)	SE55	Fuchs
	Castrol ICEMATIC SW68	Deutsche BP
	RL68 S	Uniqema
	Clavus R68	Shell
	Eal Arctic 68	EXXON Mobile
BVE32	FVC32D	Daphine Hermetic
Clavus G68	Capella WF68	Chevron
S68	Alkyl 300	BVA





Los aceites de refrigeración **BVA SUPER SERIES** tienen buena estabilidad para garantizar un buen rendimiento a altas temperaturas así como excelentes propiedades a bajas temperaturas para prevenir congelando en el evaporador. Los aceites también están libres de cera para evitar problemas de floc en el evaporador y la Válvula de expansión

## SUPER SERIES REFRIGERATION OIL

Product	3G Super	4G Super	5G Super
Viscosity @ 40° C cSt	29.6	60.14	96.8
Viscosity @ 100° C cSt	6.46	6.46	9
Viscosity @ 100° F SUS	154	316	515
Floc Point °F	-60	-50	-35
Pour Point °F	-50	-30	-20
Color	<1	<1.5	<2.0
Flash Point °F	345	365	400
Di Electric Strength KV	25	25	25
Specific Gravity @ 60° F	0.911	0.911	0.916
Aniline Point °F	175	183	197

**ACEITES BVA OILS PARA TODO TIPO DE COMPRESORES**  
**Aplicación Altas , Media y Baja Temperatura**







Fruits, vegetables, baked goods, fresh and processed meats, poultry, fish and many more.

## TS Quick Freezer ensures ultimate freshness!

### What does the TS (Time Stop) Quick Freezer system do?

Can frozen foods keep their true flavor?

When most foods are frozen, their cell membranes are destroyed which significantly reduces the taste and texture of the food. However, research has found that the original flavor, color and taste of foods can be preserved if rapid freezing is used at temperatures near -60 Celsius.

The cells are frozen so fast that they are left the freezing process.

TS Rapid Freezing prevents the destruction of food cells to ensure original flavor, taste and texture and helps to minimize flavor loss during the thawing process.



Comparison of a Conventional Freezer VS TS Quick Freezer System



# New concept cryogenic freezing warehouses

## TS rapid freezing



**Stop worrying about food corruption due to system failure!**

When two compressors are operated with an independent cold supply line, they cool to between -50 and -60 Celsius, and, although one of the compressors breaks down, the remaining compressor can only cool between -40 to -45 Celsius.

### Conventional binary cooling system

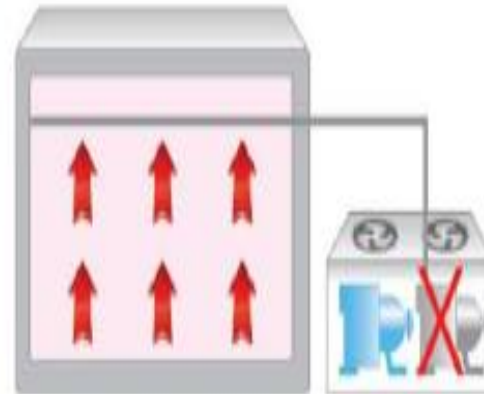
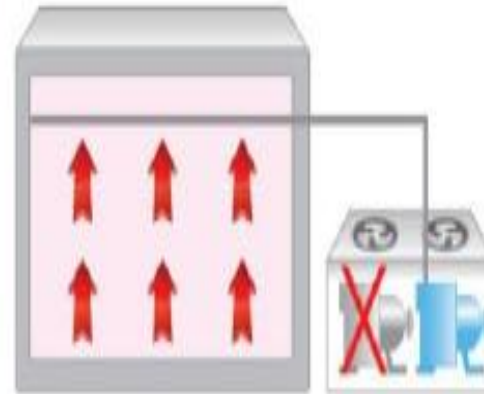

If one compressor fails,  
the internal temperature rises,

### Seilufreezer Smart Twin System

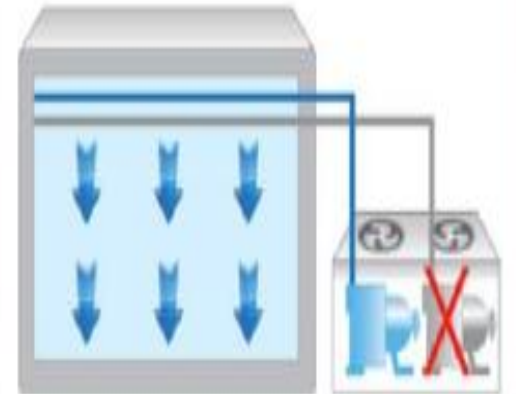
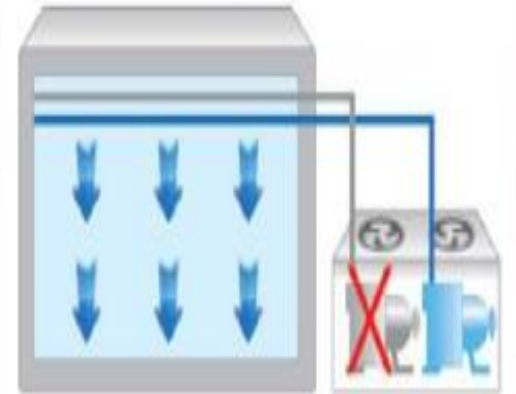

An independent cooling system keeps temperatures  
between -40 and -45 even in the event of compressor failure,



# Deep Freezer

## SF-95U500



• Temperature range : **-60°C ~ -95°C**  
(up to **-105°C**)

• Capacity : 290 / 390 / 500 / 630 liters

SEILUFREEZER

# SF-95U500

**-95°C**

- One touch filter separation
- Hot line to block Frost
- Setting double password



### Application and feature

- 95°C, 500L Cryogenic freezer( -105°C cryogenic freezer by the request)
- Long-term interpolation of drugs and vaccines and cell storage,
- Use of special Nature-friendly special mixed refrigerant (NON-CFC) which is developed by long term,
- Achieves -95 degree as one compressor and stable running system,
- Back-up rechargeable system for alarm,
- Alarm system for various safety and suitable use,
- Filter separated by one touch, which is convenient for periodic cleaning,
- Hot lines installed on the outer frame of the main body where are in contact with the outside air to prevent Frost formation,
- Double password setting function to prevent unauthorized access,
- Used 130mm High density polyurethane insulation material to minimize heat loss.



### Specifications

Models	SF-95U290	SF-95U390	SF-95U500	SF-95U630
Capacity	290 Liters	390 Liters	500 Liters	630 Liters
temp.	range	-60°C ~ -95°C		
	Sensor	PT100 Sensor		
Compressor	Hermetic Type			
Refrigerant	NON-CFC Refrigerant			
Dimension	Internal(mm)	620X515X920	620X515X1200	810X655X1200
	External(mm)	880X800X1660	880X800X1940	880X940X1940
Net weight	294KG	330KG	338KG	379KG
Electrical Capacity	AC 230V, 50/60Hz or AC 115V 60Hz			

※ Option : -105 degree product is available by the buyer's request.

Basic specification Battery backup, Automatic atmospheric pressure control, Gloves for cryogenic temperature,

Option specification Rack, Box, Co2 backup, Remote alarm system(Need to join Telecom), recorder,



SF-130C150

-130°C / 150L

SF-150C150

-150°C / 150L

Cool temperature Graph

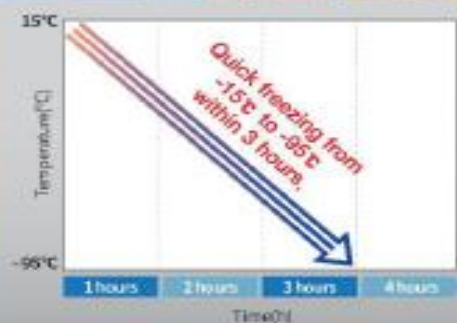

- Maximize energy saving effect and convenience by reaching from room temperature 15 degrees to -95 degrees in 3 hours (based on SF-95U500).

Structure

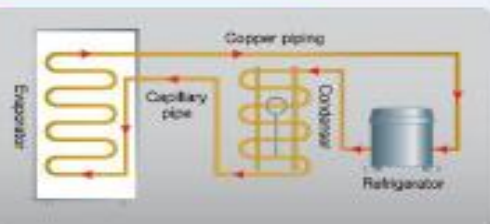

- Excellent resistance to pressure, heat, and thermal conductivity by using copper piping.

High quality  
Stainless steel  
inside room



Inside filter  
cleaning mode  
by one touch.

- Stable and low electricity consumption by Single-Hermetic type.
- Achieves Cryogenic temperature(-105 degree) by only one compressor.

- Equipment for replacement of liquid nitrogen
- Nature- friend special mixed refrigerant
- 140mm HDPU insulation

Use one compressor  
Energy saving  
model



Application and feature

- 130°C, -150°C cryogenic freezer.
- Long - term storage of drugs and vaccines and cell storage.
- This equipment can replace Liquid Nitrogen.
- Use of special Nature-friend special mixed refrigerant (NON-CFC) which is developed by long term.
- Achieves -95°C as one compressor and stable running system
- Back-up rechargeable system for alarm.
- Alarm system for various safety and suitable use.
- Double password setting function to prevent unauthorized access.
- Uses 140mm High density polyurethane insulation material to minimize heat loss.

Specifications

Models		SF-130C150	SF-150C150
Capacity		150 Liters	150 Liters
temp.	range	-90°C ~ -130°C	-110°C ~ -150°C
	Sensor	PT100 Sensor	
Compressor		Hermetic Type	
Refrigerant		NON-CFC Refrigerant	
Dimension	Internal(mm)	540X480X580	540X480X580
	External(mm)	1200X760X970	1200X760X970
Net weight		260KG	280KG
Electrical Capacity		AC 230V, 50/60Hz or AC 115V 60Hz	

- Basic specification: Battery backup, Automatic atmospheric pressure control, Gloves for cryogenic temperature.
- Option specification: Rack, Box, Co2 backup, Remote alarm system(Need to join Telecom), recorder.



ITEM	HP	MODELO	VOLTAJE (V)
Compresor MT Copeland Discus	15 HP	3DS3R17ME-TFD	440V/60HZ/3P H
Compresor MT Copeland Discus	20 HP	4DBNR20ME-TSK	440V/60HZ/3P H
Compresor MT Copeland Discus	25 HP	4DHNR22METSK	440V/60HZ/3P H
Compresor MT Copeland Discus	35 HP	6DHNR35ME-TSK	440V/60HZ/3P H
Compresor MT Copeland Discus	50 HP	6DUNR49ME- AWD	440V/60HZ/3P H
Compresor MT Copeland Discus	30 HP	4DRNR28ME-TSKCoo	440V/60HZ/3P H
Compresor MT Copeland Discus	35 HP	6DKNR35ME-TSK-Coo	440V/60HZ/3P H
Compresor MT Copeland Discus	40 HP	6DRNR40ME-TSN-Coo	440V/60HZ/3P H
Compresor MT Copeland Discus	50 HP	6DVNR49ME-AWD-Coo	440V/60HZ/3P H



**Copeland Discus™**





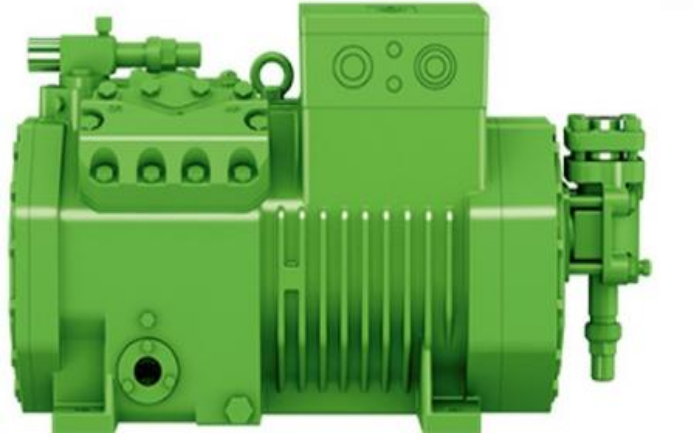

ITEM	DESCRIPCIÓN	MODELO	VOLTAJE (V)
1	COMPRESOR ECOLINE	4VES-10Y	220V/380V/3ph/60Hz
2	COMPRESOR ECOLINE	4PES-15Y	220V/3ph/60Hz PW
3	COMPRESOR ECOLINE	4PES-15Y	(440V/3ph/60Hz) PW
4	COMPRESOR ECOLINE	4HE-25Y	(440V/3ph/60Hz) PW
5	COMPRESOR ECOLINE	4GE-30Y	(380V/3ph/60Hz) PW
6	COMPRESOR ECOLINE	4FE-35Y	(440V/3ph/60Hz) PW
7	COMPRESOR ECOLINE	6FE-50Y	(440V/3ph/60Hz) PW





**Maneurop**  
RECIPROCATING COMPRESSORS

*Danfoss*



ÍTEM	DESCRIPCIÓN	MODELO	VOLTAJE (V)
1	Compresor Hermético Reciprocante	MTZ022	220/1PH/60 Hz
1	Compresor Hermético Reciprocante	MTZ022	220/3PH/60 Hz
2	Compresor Hermético Reciprocante	MTZ036	220/1PH/60 Hz
2	Compresor Hermético Reciprocante	MTZ036	220/3PH/60 Hz
3	Compresor Hermético Reciprocante	MTZ050	220/3PH/60 Hz
4	Compresor Hermético Reciprocante	MTZ064	220/3PH/60 Hz
4	Compresor Hermético Reciprocante	MTZ064	440/3PH/60 Hz
5	Compresor Hermético Reciprocante	MTZ080	220/3PH/60 Hz
5	Compresor Hermético Reciprocante	MTZ080	440/3PH/60 Hz
6	Compresor Hermético Reciprocante	MTZ125	220/3PH/60 Hz
7	Compresor Hermético Reciprocante	MTZ125	440/3PH/60 Hz
6	Compresor Hermético Reciprocante	MTZ160	440/3PH/60 Hz



Con la cámara de maduración OPTIMO de Interko, madurar fruta nunca ha sido tan fácil o versátil. OPTIMO es una solución inteligente y de llave en mano para operadores que deseen madurar de 8 a 24 palés de plátanos, aguacates o mangos en una cámara de un sólo nivel.







SEPARADOR  
DE CARGA  
AJUSTABLE



Interko

El nuevo estándar de maduración llave en mano

# DEEP FREEZER

**-95°C**



## CONGELADORAS PARA VACUNAS

- **Alcanza -95 grados como un sistema de funcionamiento estable**
- **Función de configuración de doble contraseña para evitar el acceso no autorizado**
- **Desde 290 hasta 630 litros**
- **Rango de temperatura desde -60°C hasta -95°C**



**Acero Inoxidable de alta calidad**



 **SEILUFREEZER**



# SEILUFREEZER DEEP FREEZER

• Temperature range: **-60°C ~ -95°C**  
(up to **-105°C**)

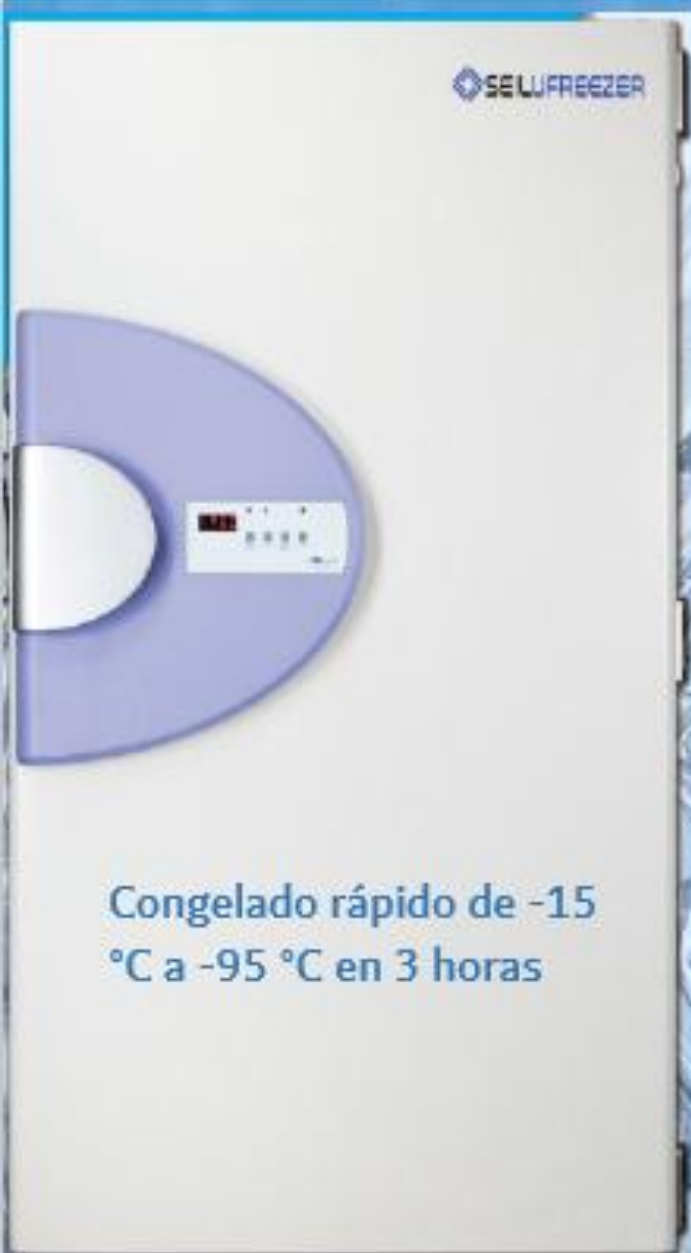

Líneas calientes instaladas en el marco exterior del cuerpo principal donde están en contacto con el aire exterior para evitar la formación de escarcha



Congelado rápido de -15 °C a -95 °C en 3 horas

## Estructura

## Grafica de temperatura

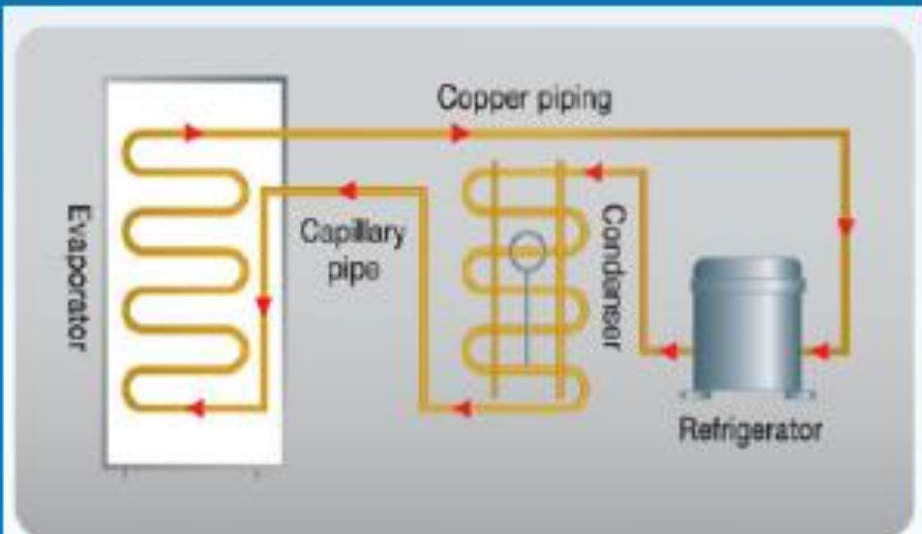

- Excellent resistance to pressure, heat, and thermal conductivity by using copper piping.

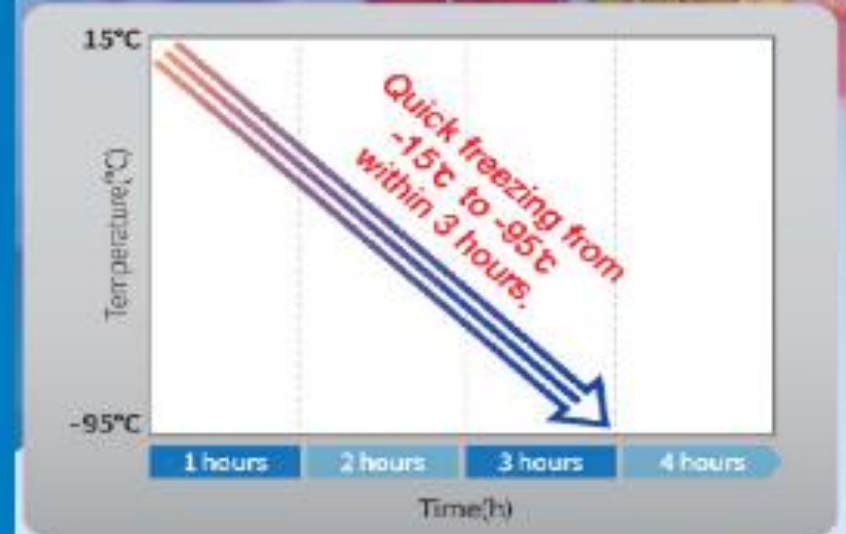

- Maximize energy saving effect and convenience by reaching from room temperature 15 degrees to -95 degrees in 3 hours (based on SF-95U500)

Models		SF-95U290	SF-95U390	SF-95U500	SF-95U630
Capacity		290 Liters	390 Liters	500 Liters	630 Liters
temp.	range	-60°C ~ -95°C			
	Sensor	PT100 Sensor			
Compressor		Hermetic Type			
Refrigerant		NON-CFC Refrigerant			
Dimension	Internal(mm)	620X515X920	620X515X1200	620X655X1200	810X655X1200
	External(mm)	880X800X1660	880X800X1940	880X940X1940	1070X940X1940
Net weight		294KG	330KG	338KG	379KG
Electrical Capacity		AC 230V, 50/60Hz or AC 115V 60Hz			







## DESCRIPCIÓN DE LA UNIDAD CONDENSADORA

Marca	DHWing
Modelo	CDAS – T1-300
Compresor	Bitzer - <b>Alemán</b> (30 HP)
Tecnología	<b>Doble Etapa Baja Temp.</b>
Modelo compresor	S6F 30.2Y
Refrigerante	R – 507A
Cap. Frig. Unit	27.85Kw
Cap. Frig. Total	55,70 Kw (02 Unid Cond)
T° Evap	-40 °C
T° Cond	+48 °C
Voltaje	440V/3PH/60Hz
Cantidad	02 (En stock)
Tipo:	Outdoor (para ambientes exteriores)



### Nota:

Las unidades condensadoras cuentan con los siguientes accesorios equipados desde **fábrica**:





## APLICACIONES

- Refrigeración Semi-Industrial e Industrial.
- Productos Frescos.
- Climatización Sala de Proceso.
- Climatización andenes de carga y pasillos.
- Industria de la Fruta, Cárnica y Pesquera.
- Centros de Distribución.
- Túneles de Pre frío.



VALVULAS Y CONTROLES CAREL - KIT DE VÁLVULAS ELECTRONICA; (PARA EXPANSIÓN DE REFRIGERANTE)



PARA LOS TÚNELES DE CONGELADO

VALVULAS Y CONTROLES CAREL



El sistema estará regulado por válvulas de refrigeración marca Carel, las válvulas incluyen válvulas de **expansión electrónica por paso**, visores y filtros, necesarios para ambos ambientes







**KIT DE VÁLVULAS DE EXPANSIÓN ELECTRÓNICAS PARA  
1 BLOQUE EVAPORADOR CON 02 CIRCUITOS INTERNOS  
TIPO PASO (MODULAR)**

EL KIT COMPRENDE:

ITEM	CODIGO	DESCRIPCIÓN	CANT	U.M.
1	EVD0000T50	Driver EVD evolution TWIN para dos válvulas electrónicas de expansión con comunicación RS485 / Modbus®	1,00	UNID
2	EVDI500E50	Pantalla para EVD evolution (SINGLE y TWIN) en Español	1,00	UNID
3	TRADRFE240	Transformador 230/24 Vac, 35 VA, instalación en riel DIN con fusible	1,00	UNID
4	E3V5555500	Válvula electrónica de expansión E3V55, conexiones de cobre de 22-28 mm, tornillo integral, con mini llave	2,00	UNID
5	E2VC485500	Cable para válvula electrónica de expansión, L= 6 m	2,00	UNID
6	NTC060HF01	Sonda de temperatura para sobrecalentamiento con correa, L= 6 m, IP67, -50T30 °C	2,00	UNID
7	SPKT0033F0	Transductor de presión, salida 0..5 V, 0 a 34,5 bar (0 a 500 PSI) Para presión de succión	2,00	UNID
8	SPKC005310	Cable para transductor de presión, L= 5 m, IP67	2,00	UNID
9	EVD0000UC0	Módulo UltraCap para cerrar la válvula en caso de apagón OPCIONAL (no se necesita instalar si hay válvula solenoide)	1,00	UNID

**STOCK**





Refrigeración S.A

<https://hbrefrigeracion.com>

Geidy Chavez B.

Ejecutiva de Ventas

Telf: (511) (01)418 28 21

Cel. 913 008 362

E-mail: [gchavez@hbrefrigeracion.com](mailto:gchavez@hbrefrigeracion.com)

Calle los Halcones 523, oficina 201, Surquillo - Lima - Perú

